

DIGGER PLANT

EARTH MOVING

BRIAN JAMES TRAILERS

» Connected to you



UNITED KINGDOM

DIGGER PLANT



DIGGER PLANT EARTH MOVING

***5**
**5 YEAR
EXTENDED
WARRANTY**



The innovative **Digger Plant** range provides a modern, advanced and compliant transport solution for many tracked excavators and plant machines such as chippers and shredders. With obvious appeal to larger organisations, the ideas pioneered in the **Digger Plant** also translate to smaller fleets and individual users interested in efficiency and safety.

Being a part of the Brian James Trailers range, **Digger Plant** features a low ride height for optimal distribution of weight and stable towing performance.



* 1 year warranty as standard. Additional 4 year warranty period requires product registration.

DIGGER PLANT

DIGGER PLANT

STANDARD FEATURES

Highest capacity

Digger Plant has a gross capacity of 2,700kg or 3,500kg. It combines this with class leading light, but tough chassis design to achieve unrivalled payload capability. Whether moving diggers or dumpers our advanced low chassis design and versatile layout, achieves recommended weight distribution, ensuring stable and safe towing.

The deck design is constructed using heavy duty phenol ply (18mm), with substantial under deck chassis reinforcements. Even the heaviest machinery such as road rollers or mini diggers will not cause damage. Robust steel mudguards and all around high-grip side steps provide easy and safe access to machinery on the trailer.

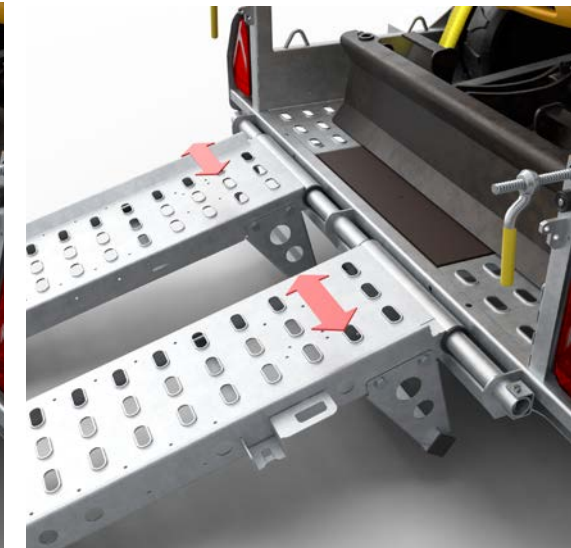

- **Long drawbar** provides plenty of space for digger arms.

- **Jockey wheel**
Heavy duty jockey wheel. Features anti-vibration latch and is positioned away from conflict with loaded machinery.

- **Adjustable punched ramps** provide low loading angle for all types of vehicles. Each ramp can be positioned across the full width in seconds. Constructed from galvanised steel, punched for high grip. Unique nylon hinge sleeves eradicate unwanted rattles and wear.



MULTIPLE ANCHOR POINTS

- **Multiple anchor points**
Numerous strap attachment points are located in the chassis providing ultimate strength. A high level of grip and strength is offered by the raised, punched profile of each slot. Machine restraint is made easy with many tie-down options.



- **Spare wheel**
Mounted conveniently towards the front of the trailer.



HIGH-GRIP SURFACE

- **High grip**
Features high strength punched and formed steel. Provides grip and is extremely resistant to wear, even on tough jobs.

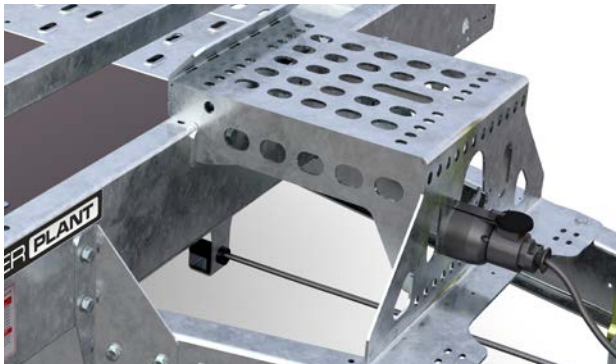

● **Universal bucket rest**
Standard fitment on Digger Plant trailers.



● **ACME thread clamps.** Silent locked – the loading tail ramp is held in place with secure clamp fasteners. A rubber buffer is part of the system and provides damping for quiet travel.

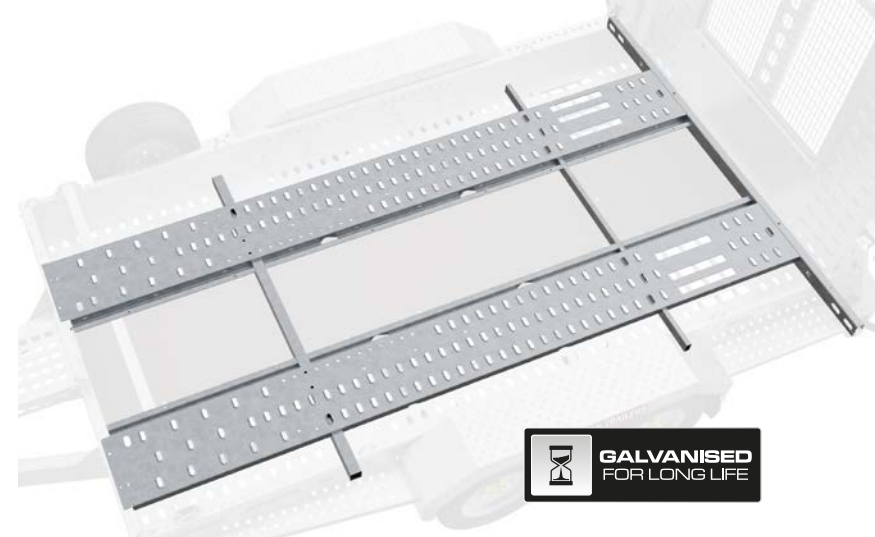

● **Super-structure**
The strength of Digger Plant is more than skin deep. Super-strength steel used in the main chassis fabrication is complemented by two additional longitudinal beams just below the 18mm phenol ply anti-slip centre bed. Lighter weight and improved strength, combined with the durability of a hot-dip galvanized chassis ensures that Digger Plant will serve for many years.

● **Smooth-ride, self damping**
Digger Plant trailers are designed for long distance and heavy loads. Axles and suspension technology is proven beyond doubt.



● **50mm ball coupling head** with security lock.

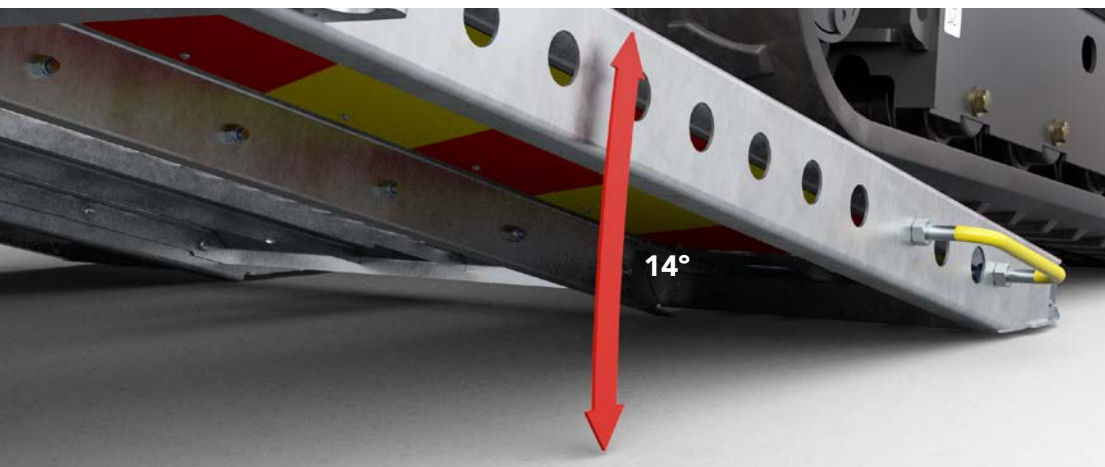

● **Low loading angle**
The Digger Plant features a loading angle of 14° which enables easy loading and unloading of machines.

● Standard. ○ Optional at extra cost.

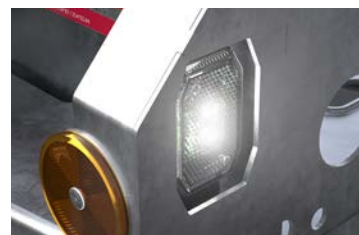

● **Full LED lighting**
LED lights are both super bright and reliable. All lamps are LED technology as standard.

LED lamps: Note
LED lamps are not compatible with all towing vehicles. This may cause unintended consequences. Please check compatibility.



DIGGER PLANT

OPTIONS

Does the job, better

A full working specification as standard gets the job done. We also know that each operator has differing requirements and have catered for this with an unrivalled range of optional configurations, each available at the time of order, or as a retro-fit.

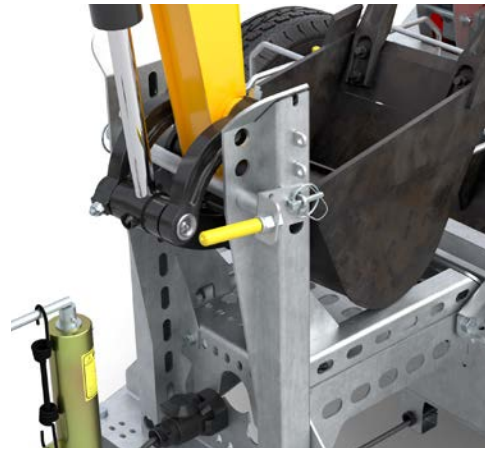

○ Digger Arm Lock
Guides and secures the digger arm and bucket to the trailer with a single heavy duty locking pin.

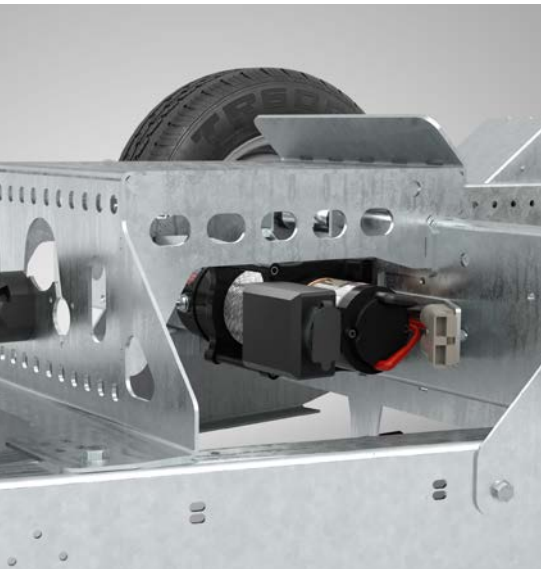

○ Electric winch
12V electric winch kit with 4500lb drag capacity and wander lead remote control. Power pack available separately.



○ Manual winch
Manually operated winch with steel cable, auto braked operation with free spool and centre pulley guide.

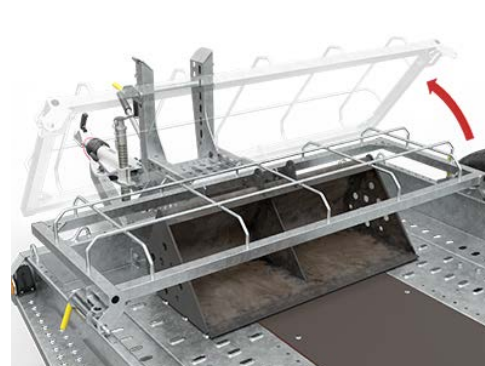

○ Bucket locker
Secure lockable storage for digger buckets and other attachments.



○ Chapter 8 Chevrons provide compliance with vehicle marking regulations for sites. (Shown with optional reinforced centre infill mesh panel kit for twin ramp tail panel).



○ Wheel safety indicators

Visually reveal whether wheel nut torque has changed once originally set.

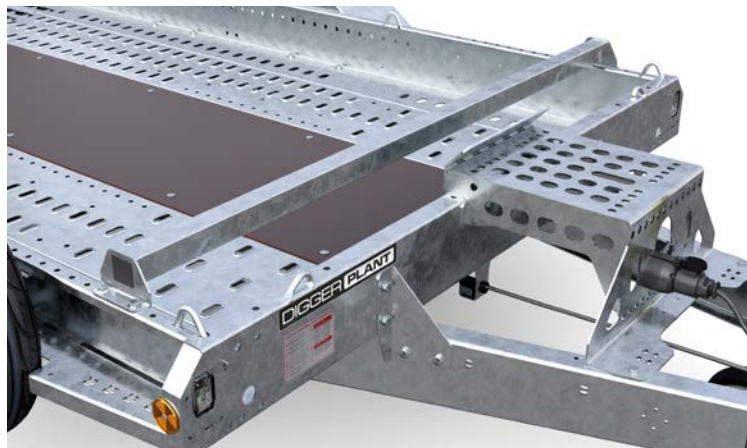

○ Machine stop bar designed to provide a reliable stop for digger and plant machinery. Must be used in combination with tie-down restraint straps.



○ Heavy Duty spring assisted tail lift ensures that lifting operation regulations are easily met.



○ TracStrap system

The Tracstrap system is unique to Brian James Trailers and the Digger Plant. This in-house designed and manufactured system offers extremely high levels of towing security with minimal effort (TÜV Nord test report 8114838799). The front chocks are adjustable and provide a fixed loading point. Each track is held in place by a 5 tonne rated 50mm wide straps featuring heavy duty wear protectors.

○ 40mm eye coupling

Available for applications in which a pin and eye coupling is required.



DIGGER PLANT

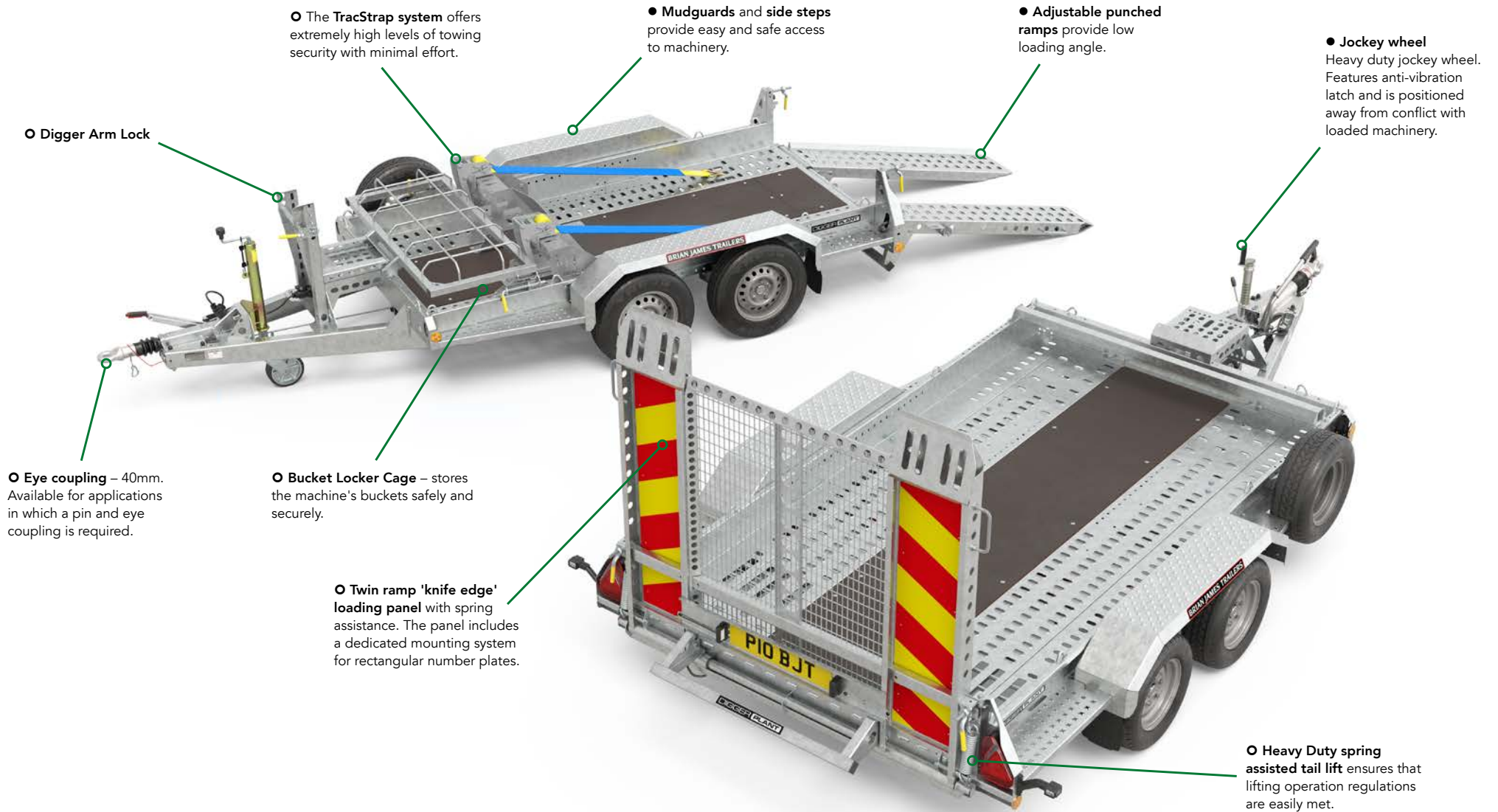

○ The **TracStrap system** offers extremely high levels of towing security with minimal effort.

● **Mudguards and side steps** provide easy and safe access to machinery.

● **Adjustable punched ramps** provide low loading angle.

● **Jockey wheel**
Heavy duty jockey wheel. Features anti-vibration latch and is positioned away from conflict with loaded machinery.

○ **Digger Arm Lock**

○ **Eye coupling** – 40mm. Available for applications in which a pin and eye coupling is required.

○ **Bucket Locker Cage** – stores the machine's buckets safely and securely.

○ **Twin ramp 'knife edge' loading panel** with spring assistance. The panel includes a dedicated mounting system for rectangular number plates.

○ **Heavy Duty spring assisted tail lift** ensures that lifting operation regulations are easily met.

TECHNICAL INFORMATION

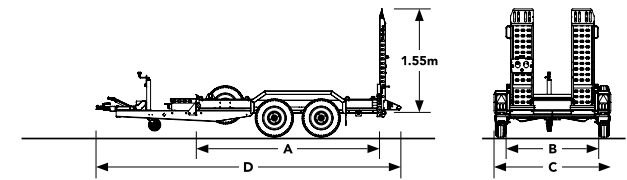

PRODUCT CODE	543-0110	543-1320	543-2320
CAPACITY			
Gross kg	2,700	3,500	3,500
Load kg	2,158	2,818	2,773
Unladen trailer weight kg	542	682	727
DIMENSIONS			
Load bed length m A	2.80	3.20	3.70
Internal bed width m B	1.30	1.70	1.70
Overall trailer width m C	1.79	2.32	2.32
Overall trailer length m D	4.65	5.12	5.12
Bed load height m	0.38	0.40	0.40
Towball height (loaded, centre of towball) m	0.40	0.40	0.40
Working load angle	14°	14°	14°
RUNNING GEAR			
Axles	2	2	2
Wheel / Tyre size	13" (165 6pr)	12" (195/60)	12" (195/60)
Heavy duty jockey wheel	●	●	●
Locking tow hitch	●	●	●
STANDARDS / WARRANTY			
Directive 200/46/EC approval	●	●	●
Galvanised steel - EN ISO 1461	●	●	●
5 year extended chassis warranty - 1 year warranty as standard. Additional 4 year warranty period requires product registration	●	●	●
REAR LOADING			
Adjustable position "high grip" punched ramps x 2	●	●	●
Twin ramp "knife edge" loading panel + spring assistance and reinforced centre infill mesh panel	○	○	○
LIGHTING			
Full LED lighting	●	●	●
LOADING, WHEELS AND SECURITY			
Spare wheel	●	●	●
Bucket locker cage - Store buckets in front of the digger safely	○	○	○
Machine stop bar - Adjustable full width bar	○	○	○
TracStrap system - Secure + easy strapping system incorporating track stops	○	○	○
Digger arm lock - Safe towing aid	○	○	○
Tie-down anchor points (internal)	Multiple in platform		
Eye coupling - 40mm	○	○	○
Tie-down straps	○	○	○
Chapter 8 chevrons - Site regulation compliant vehicle markings	○	○	○
Wheel nut indicators - Wheel sentry kit	○	○	○

● Standard ○ Optional at extra cost

All trailer weights stated are approximate and are based on a trailer with no optional extras fitted.

DIGGER PLANT

QUALITY

Brian James Trailers are manufacturers of class leading trailers since 1979. When you buy a Brian James Trailer you can be absolutely certain that it is designed and constructed to the highest possible standards. Our engineers combine top-quality craftsmanship with the best materials and first-class presentation. Light but strong, our trailers are crafted to enhance safety, efficiency and durability.

5 Year Extended Chassis Warranty

All of our trailers come with a standard 1 year non-transferable manufacturer's warranty covering the integrity of the chassis, which can be extended to 5 years at no additional charge upon registration.

This 5 year extended warranty applies to the chassis only. All other components are subject to a standard 1 year warranty, subject to fair wear and tear.

Standards

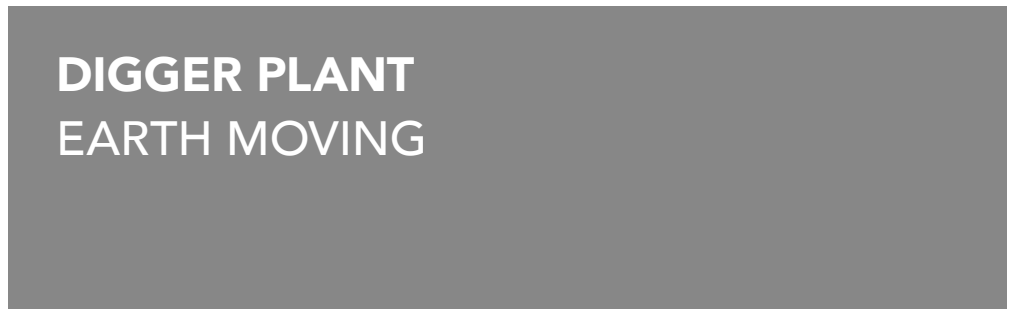



DIGGER PLANT

BRIAN JAMES TRAILERS

» Connected to you

NOTES

All images used are for illustrative purposes only and may show non-standard equipment and finishes.
All products are subject to change without prior notice due to our continuous development programme.

© BRIAN JAMES TRAILERS LIMITED

Edition DIGPL-UK2022_Q1_1



THE QUEEN'S AWARDS
FOR ENTERPRISE:
INTERNATIONAL TRADE
2018

Brian James Trailers Limited.
Sopwith Way, Drayton Fields Industrial Estate
Daventry, Northampton, NN11 8PB

T + 44 (0)1327 308 833

Brian James Trailers are available by contacting our sales team as well as through an extensive network of official dealers throughout the country.

For more information please call or visit our website.

www.brianjamestrailers.co.uk

Dealer information

